

AMC740 / AMC740C – Processor AMC, Tileria GX72, 72 Core

Processor AMC, Tileria GX72

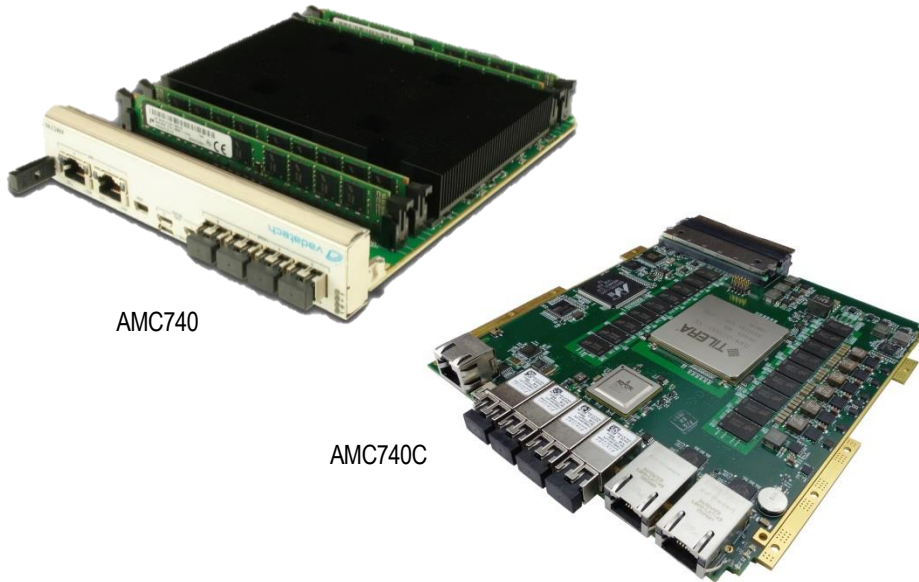

KEY FEATURES

- Tileria™ GX72CPU with 72 TILE-Gx Core processors
- Conduction cooled version available
- Double module, full-size per AMC.0
- Four banks of DDR3 w/ ECC (up to 64 GB)
- AMC Ports 4-11 are routed to Tileria per AMC.1, AMC.2 (PCIe and XAUI options)
- AMC Ports 17-20 optionally routed as XAUI to the Tileria
- Four 10 GbE to front panel
- IPMI 2.0 compliant

AdvancedMC™

Benefits of Choosing VadaTech

- High performance with 72 processor cores (tiles) on Tileria™ chipset
- High bandwidth front-panel and backplane connectivity
- QoS queuing and traffic shaping support
- Strong mil/aero support
- Electrical, mechanical, software, and system-level expertise in house
- Full system supply from industry leader
- AS9100 and ISO9001 certified company

The AMC740 is ideal for packet filtering, intelligent networking, multimedia, video transcoding, cloud and other applications. The device includes 72 identical processor cores (tiles) interconnected with Tileria's iMesh™ on-chip network. Each tile consists of a full-featured, 64-bit processor core as well as L1 and L2 cache and a non-blocking Terabit/sec switch. The high processing density and high internal bandwidth of the GX72CPU make it ideal for intensive computing tasks.

The AMC740 provides four 10 GbE front-panel ports via LC style connectors, making it suitable for network-centric sensor processing applications. The unit includes IEEE 1588v2 precision timing controller support, which provides precision 1 ns granularity packet timestamping for signal encoding.

The AMC740 is available in both air-cooled (MTCA.0 and MTCA.1) and rugged conduction-cooled (MTCA.2 or MTCA.3) versions.

AMC740

BLOCK DIAGRAM

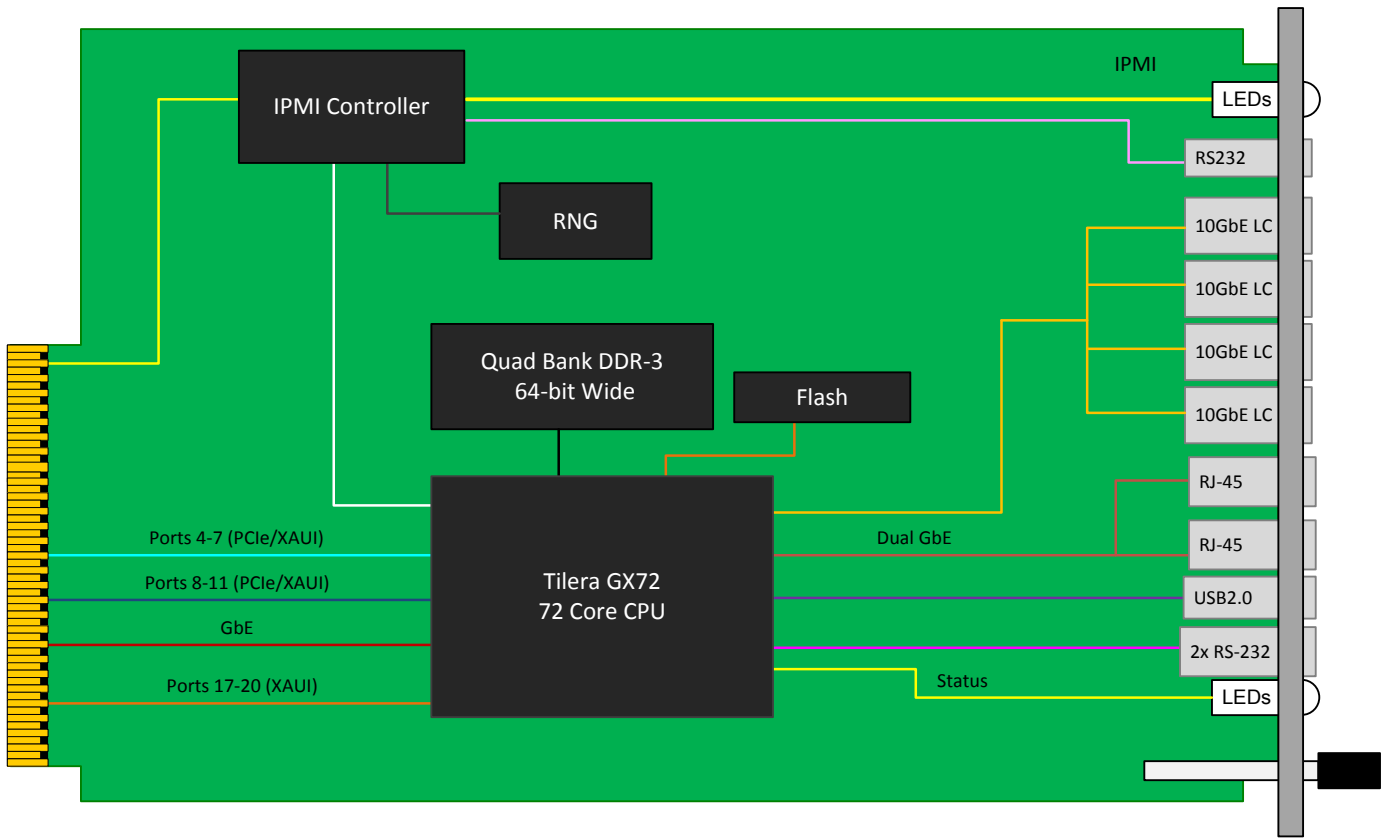

Figure 1: AMC740 Functional Block Diagram

FRONT PANEL

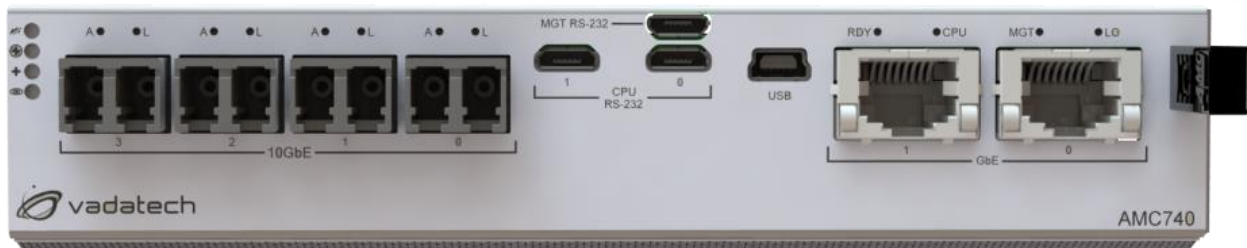

Figure 2: Front Panel

AMC740 / AMC740C – Processor AMC, Tiler GX72, 72 Core

AMC740C

VadaTech offers the AMC740 in a rugged clamshell variant, available as either MTCA.3 (conduction cooled) or MTCA.2 (hybrid cooled, forced air and conduction). For these versions of the module the ground planes are extended into the wedge lock region of the clamshell to enhance thermal transfer, as shown above. Such units are typically used in ATR style chassis such as the VT87x series.

BLOCK DIAGRAM

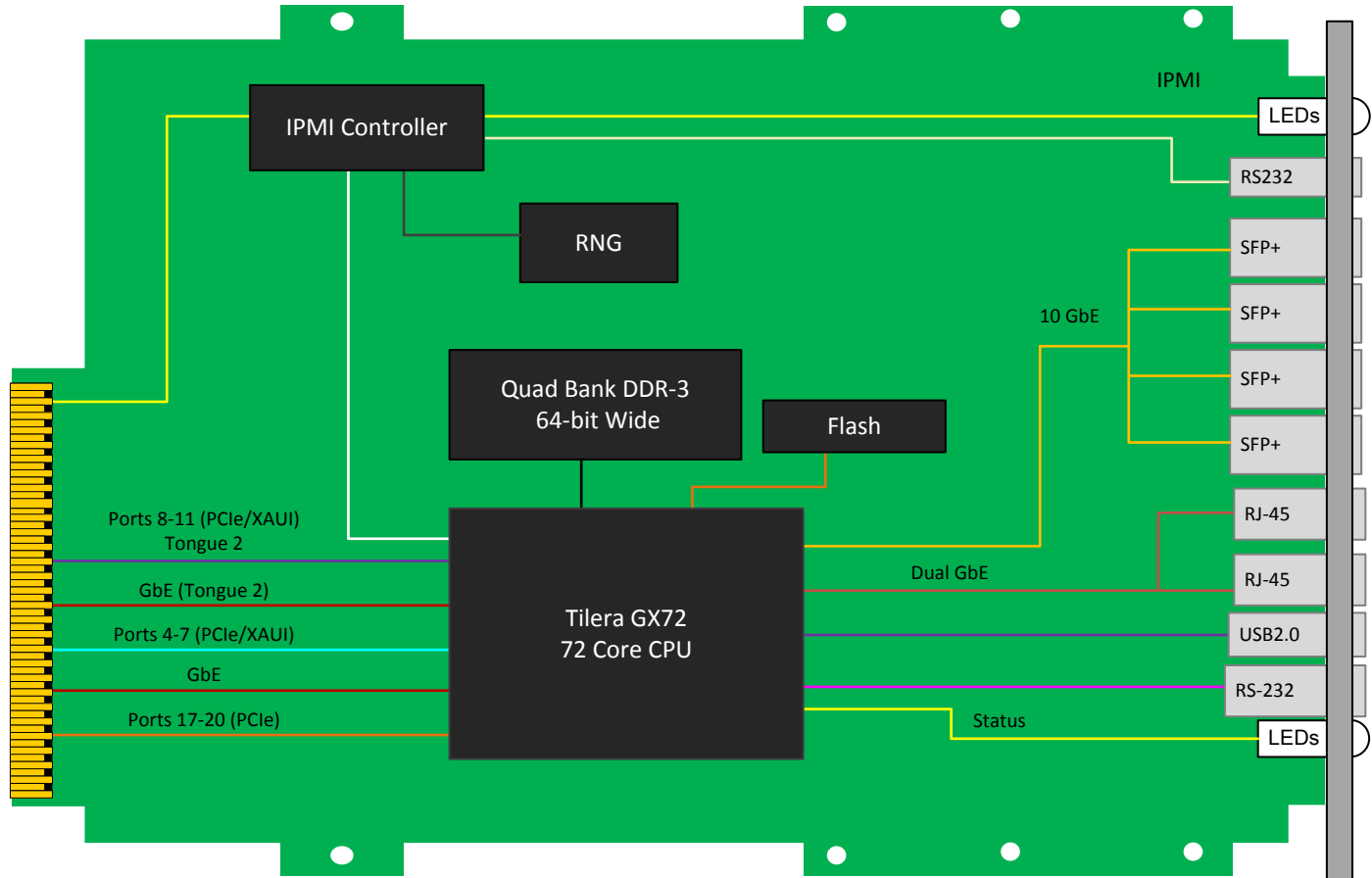

SPECIFICATIONS

Architecture		
Physical	Dimensions	Double module, mid and full-size options
		Width 5.85 in. (148.5 mm)
		Depth 7.11 in. (180.6 mm)
Type	AMC	72 Core PrAMC, Tiera GX72
Standards		
AMC	Type	AMC.1 and AMC.2
Configuration		
Power	AMC740	80 W
Environmental	Temperature	Operating temperature: -5° to 45° C (55°C for limited time, performance restrictions may apply), industrial and extended versions also available (See environmental spec sheet)
		Storage Temperature: -40° to +85° C
		Altitude
	Relative Humidity	5 to 95 percent, non-condensing
Front Panel	Interface Connectors	2x RS-232, 4x LC connectors, 2x RJ-45, USB 2.0, LEDs
LEDs	Type	IPMI management, Activity, GPIO
Conformal Coating		Humiseal 1A33 Polyurethane (Optional)
		Humiseal 1B31 Acrylic (Optional)
Operating System	Type	Linux (consult VadaTech for other options)
Other		
MTBF	MIL Hand book 217-F @ TBD Hrs	
Certifications	Designed to meet FCC, CE and UL certifications where applicable	
Standards	VadaTech is certified to both the ISO9001:2000 and AS9100B:2004 standards	
Warranty	Two (2) years	

INTEGRATION SERVICES AND APPLICATION-READY PLATFORMS

VadaTech has a full ecosystem of ATCA and μ TCA products including chassis platforms, shelf managers, AMC modules, Switch and Payload Boards, Rear Transition Modules (RTM), Power Modules, and more. The company also offers integration services as well as pre-configured Application-Ready Platforms. Please contact VadaTech Sales for more information.

Trademarks and Disclaimer

The VadaTech logo is a registered trademark of VadaTech, Inc. Other registered trademarks are the property of their respective owners. AdvancedTCA™ and the AdvancedMC™ logo are trademarks of the PCI Industrial Computers Manufacturers Group. All rights reserved. Specification subject to change without notice.

ORDERING OPTIONS

AMC740 – ABC – D0F – 0HJ

A = 10GbE on Ports 17-20

0 = Not connected

1 = Connected

B = CPU

0 = 1.0 GHz

1 = 1.2 GHz

C = Front Panel Size

1 = Reserved

2 = Reserved

3 = Full-size (6 HP)

D = DDR3 Memory w/ECC

0 = 16 GB

1 = 32 GB

2 = 64 GB

F = PCIe Option

0 = No PCIe

1 = PCIe on ports 4 – 7

2 = PCIe on ports 8 – 11

3 = PCIe on ports 4 – 11

H = Operating Temperature

0 = Commercial (-5° to +45° C)

1 = Industrial (-20° to +70° C)

2 = Extended (-40° to +85° C)

J = Conformal Coating

0 = None

1 = Humiseal 1A33 Polyurethane

2 = Humiseal 1B31 Acrylic

AMC740C – 0BC – D0F – 0HJ

B = CPU

0 = 1.0 GHz

1 = 1.2 GHz

C = Ruggedization Level*

0 = None

1 = Contact Vadatech

2 = Contact Vadatech

3 = Contact Vadatech

D = DDR3 Memory w/ECC

0 = 16 GB

1 = 32 GB

2 = 64 GB

F = PCIe Option

0 = No PCIe

1 = PCIe on ports 4 – 7

2 = PCIe on ports 8 – 11

3 = PCIe on ports 4 – 11

H = Operating Temperature **

0 = Commercial (-5° to +45° C)

1 = Industrial (-20° to +70° C)

2 = Extended (-40° to +85° C)

J = Conformal Coating

0 = None

1 = Humiseal 1A33 Polyurethane

2 = Humiseal 1B31 Acrylic

* Ruggedization level is per the uTCA.2 and uTCA.3 specifications

** Edge of module

RELATED PRODUCTS



**VT899 7U uTCA, 6 AMC
Cube Chassis**



**UTC004 Gen 3
MCH**



**VT872 1/2 ATR Short, 6 AMC
Conduction Cooled Chassis**

CONTACT US

VadaTech Corporate Office

198 N. Gibson Rd.
Henderson, NV 890142
Email: info@vadatech.com
Telephone: +1 702 896-3337
Fax: +1 702 896-0332

Asia Pacific Sales Office

7 Floor, No. 2, Wenhua Street, Neihu District,
Taipei 114, Taiwan
Email: info@vadatech.com
Telephone: +886-2-2627-7655
Fax: +886-2-2627-7792

VadaTech European Sales Office

VadaTech House, Bulls Copse Road,
Southampton, SO40 9LR
Email: info@vadatech.com
Telephone: +44 2380 016403